



Premises Department, Regd. Office, No. 29/1, Sir M N Krishna Rao Road,
Basavangudi, Bangalore 560004
[Phone No 080-26567659 Fax No: 26565746 Email: admindep@canfinhomes.com]

RFP FOR " Supply/erection/installation of the Mobile Rack Compactors"

TENDER REFERENCE NO: RFP – 01/20-21

DATE OF TENDER DOCUMENT:	08/09/2020
LAST DATE FOR SUBMISSION OF TENDER:	18/09/2020 (UPTO 03.00 PM)
DATE OF OPENING OF TECHNICAL BID:	18/09/2020 (AT 03.30 PM)
COST OF TENDER DOCUMENT:	
EARNEST MONEY DEPOSIT:	
NO. OF PAGES:	5 Pages

**ISSUED BY:
CHIEF MANAGER
PREMISES DEPARTMENT
CANFIN HOMES LTD
REGISTERED OFFICE,
29/01, SECOND FLOOR,
SIR M N KRISHNA RAO ROAD,
BASAVANGUDI,
BANGALORE 560004**

Contact Numbers: Tel - 080- 26567659

Fax- 080-26565746

Email: admindep@canfinhomes.com

This document can be downloaded from Company's website
<http://www.canfinhomes.com>



Registered Office
29/1, First Floor,
Sir M N Krishna Rao Road,
Basavangudi Bangalore 560004

Registered office, Bangalore

Closed tenders are invited from suppliers of Mobile Rack compactors who have supplied and installed similar Compactors in our company/Canara Bank or any nationalized bank for supply / erection/installation of the additional Mobile Rack Compactors at **II floor, 39, Subramanyapuram main road, Chikkalasandra, Near Prarthana School, Bangalore - 560 061**. The details of requirement is as follows:

BILLS OF QUANTITIES

Description	Qty	Height mm	Width mm	Depth mm	Rate	Total Amount
System A						
Single Faced Fixed (A) with 4 Comp	1 No	2286	3660	406		
Double Faced Mobile (B) with 4 Comp	11 Nos	2286	3660	812		
Double Faced Mobile (C) with 4 comp	1 No	2286	3660	812		
System B						
Single Faced Fixed (A) with 4 Comp	1 No	2286	3660	406		
Double Faced Mobile (B) with 4 Comp	10 Nos	2286	3660	812		
Double Faced Mobile (C) with 4 comp	1 No	2286	3660	812		
Sub Total						
Add: Delivery / Installation charges, if any						
Add: Applicable GST						
GRAND TOTAL						
Amount In words: -						

The quantities are subject to variation.

Drawing with measurements is available for your reference

Technical Specification for Supply of Mobile Rack Compactors (Drawing attached separately)

01. **Base Frame:** Base frame should be fabricated in channel type from minimum 3 mm thick MS. Sheet size of Channel 25mm X 100mm X 45mm.

02. **Guide Rails:** The guide rails should be made out of 28mm Bright bar paced within 'C' channel size of 36mm X 24mm X 1.6mm thick which should be above the floor and are as per the international standard of safety and the slopes on both sides of the track.

03. **Superstructure:** Super structure of the Mobile Rack System should consist of knock down type panels. All the components such as shelves, front panel, vertical rear panel, central partition will act as an integral member of the unit.

04. **Shelves:** Shelves should be made up of 20 SWG (1mm) thick C.R.C.A. quality steel having 8 folds each should be provided, each to be designed to carry a U. D. L. of 100 Kgs.

05. **Vertical Panel:** Vertical Panel consists of the front, centre & rear panel should be made out 20SWG (1mm) thick C. R. C. A. Prime quality steel. All the shelves are to be fitted on the side & front panel having one row of holes on each of the flanges at a pitch. The holes of the flanges will provide flexibility in fixing the shelves at any desired height.

06. **Drive Cover panel:** Made out of 20SWG (1mm) thick C. R. C. A. prime quality steel to cover the entire drive mechanism.

07. **Centre Partition:** The centre partition will comprise of a full C. R. C. A. prime quality 22SWG (0.8mm) sheet.

08. **Swing Doors:** Made out of 22 SWG (1mm) thick C. R. C. A. prime quality steel with lock and key.

09. **Safety Provision:**

Locking system should be provided on every unit. It should be consist of two types

- A. Temporary locking by means of locking pin, to ensure that a particular carriage under operation is locked, thereby prevents any accidental jamming, when working inside the aisle.
- B. Central locking device facilitating locking of entire system: Locking by means of special lock and key, should ensure locking of entire system and access to only authorized person.
- C. Stoppers are to be provided at the end of rails to prevent derailment of the carriage while in operation.

10. **Drive Mechanism:** Driving Mechanism should be provided externally supported on special grade anti-friction bearing to have smooth & effortless movement. Entire mechanism or gear & sprockets shall be incorporated within the front panel provided in the front of the unit within an area of 1000mm x 200mm x 50mm.

11. **Indexing Arrangement:** Self-sticking card holders should be provided on the front panel for easy identification & retrieval.

12. **Driving Wheel:** Fully powder-coated three pronged drive wheel for better torque & free movement of the rack over the guide rails.

13. Entire Unit should be provided with powder coated finish

Bidders are requested to visit the site, clarify themselves clearly before submitting the bids.

1. General Instructions:

a) Two Bid System Offer:

There should be two separate bids (Technical Bid and Commercial Bid). Both Technical and Commercial Bids shall be submitted in English language in font size 12 point in separate sealed envelopes, super scribing "Technical Bid" on the top of the cover of Technical Bid and "Commercial Bid" on the top of the cover of Commercial Bid. The sealed envelopes containing Technical and Commercial Bid shall be submitted in another sealed envelope super scribing "Offer for supply / erection/installation of Mobile Rack computers (includes separately sealed Technical Bid and Commercial Bid)" on the top of the envelope. The Name of the Bidder and Due Date of the RFP are to be specified on the top of the envelope.

The bid/s should be deposited in the **Premises Department, Can Fin Homes Ltd, 29/01, Sir M N Krishna Rao Road, Basavangudi, Bangalore – 560 004**, on or before **Friday 18th Sep 2020, 03:00 PM**.

If last day of submission of bids is declared a holiday under NI Act by the Government subsequent to issuance of RFP the next working day will be deemed to be the last day for submission of the RFP. The Bid/s which is/are deposited after the said date and time shall not be considered. No offer will be accepted directly. The Technical Bid/s will be opened in the presence of the bidder's representative on the offer due date **Friday 18th Sep 2020, 03:30 PM** at Premises Department, Can Fin Homes Ltd, 29/01, Sir M N Krishna Rao Road, Basavangudi, Bangalore – 560 004. Bidder's representative may be present in the venue well in time and should sign in Register of Attendance.

On verification of Technical bid, commercial bid will also be opened immediately.

A copy of purchase order issued by Canara Bank /Any Nationalized Bank/our company for executing similar work should be enclosed along with bid covers.

The Offer submitted and the prices quoted therein shall be valid for 6 months from the last date for submission of the quotation.

No offer can be modified or withdrawn by a bidder after submission of quotation.

The Company reserves its right to reject any or all the offers without assigning any reason thereof whatsoever.

The Company will not be obliged to meet and have discussions with any bidder and/ or to entertain any representations in this regard

2. Pricing & Payments

2.1. The Price offered to the Company must be in Indian Rupees, and inclusive of Duties/Insurance/Freight but Exclusive of all taxes. The Vendor has to quote the applicable taxes separately.

2.2. The item value along with GST should be claimed in the invoice, location wise and GST will be paid in actual at our end. However please note that taxes will be paid to the maximum of taxes indicated in the Bill of Material.

2.3. No escalation in price quoted is permitted for any reason whatsoever. Prices quoted must be firm till the completion of the contract.

2.4 Please note that no extra charge/ tax will be paid for those locations where road permit is required. Vendor only has to arrange for road permit at his cost. It

will be the sole responsibility of the vendor to submit any form required for release of shipment from the check post.

2.5 The Company will not arrange for any Road Permit / Sales Tax clearance for delivery of items to different locations and the Vendor is required to make the arrangements for delivery of items to the locations as per the list of locations / items provided from time to time by the Company. However, the Company will provide letters / certificate regarding placing of order / authority to the Vendor, if required.

3. Payment Terms

3.1. Payment terms will be 100% on supply/erection/installation and on smooth functioning of the Mobile Rack Compactors at our proposed Central storage system at **11 floor, 39, Subramanyapuram main road, Chikkalasandra, Near Prarthana School, Bangalore - 560 061.**

4. Time schedule for execution: 5-6 weeks from the date of purchase order

5 Order Cancellations

The Company reserves its right to cancel the entire / unexecuted part of the Purchase Order at any time by assigning appropriate reasons in the event of one or more of the following conditions:

1. Delay in delivery beyond the specified period for delivery.
2. Serious discrepancies noted in the items delivered.
3. Breaches in the terms and conditions of the Order.

6. Indemnity

The vendor shall indemnify, protect and save the Company against all claims, losses, costs, damages, expenses, action suits and other proceedings, resulting from infringement of any law pertaining to patent, trademarks, copyrights etc. or such other statutory infringements in respect of all the hardware items supplied by him.

7. The jurisdiction of the court

The jurisdiction of the court is at Bangalore.

8. Contact details:

1. Contact Person: 1. S. Mohana Krishnan, Chief Manager, Premises Department
2. K Srikanth, Officer Tel: 080-26567659

Email: admindep@canfinhomes.com Web: www.canfinhomes.com

We have installed mobile rack compactors at First floor of our Uttarahalli Bangalore branch & Second floor of our Ramachandrapuram, Hyderabad. Those who wish to visit these two branches may contact Mr Srikanth K, Officer 080-26267659

Chief Manager
Premises Department

Date: 08/09/2020

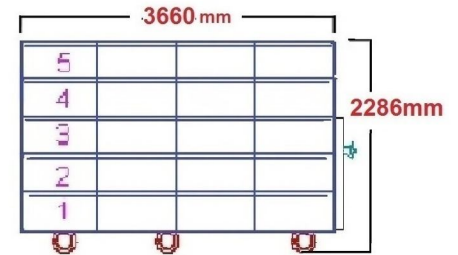
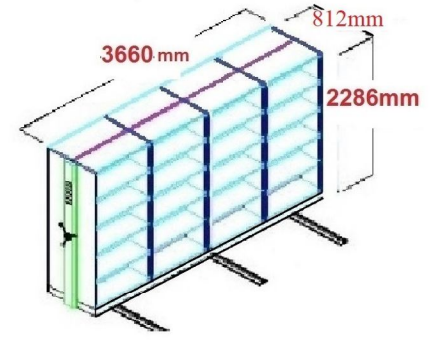
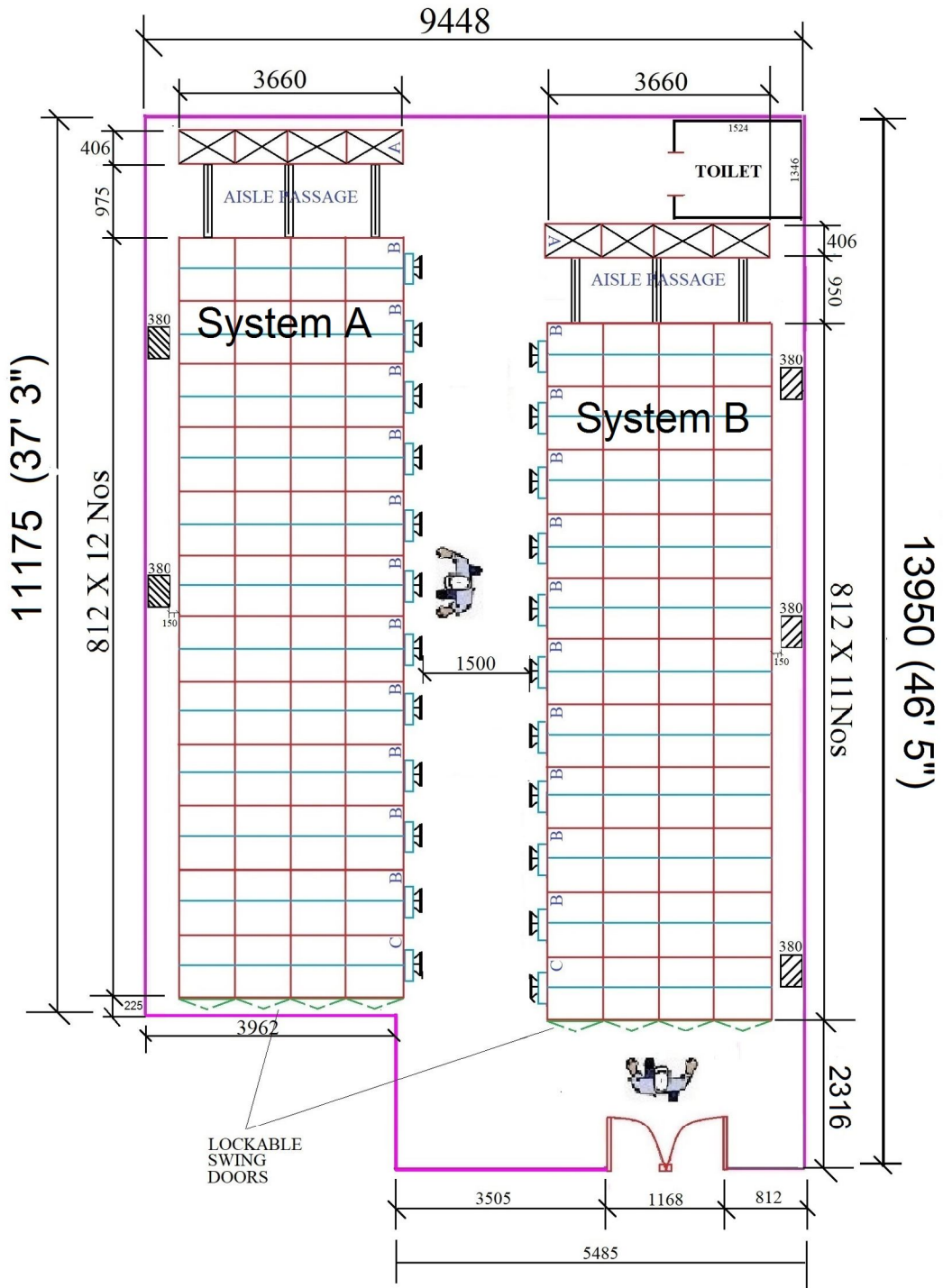

SYSTEM A&B

SIDE ELEVATION

4 BAYS MOBILE RACK SYSTEM A				
DESCRIPTION	QTY	HEIGHT	WIDTH	DEPTH
SINGLE FACED FIXED UNIT (A)	1 No	2286	3660	406
DOUBLE FACED MOBILE UNIT (B)	11 Nos	2286	3660	812
DOUBLE FACED MOBILE UNIT WITH DOOR(C)	1No	2286	3660	812
4 BAYS MOBILE RACK SYSTEM B				
DESCRIPTION	QTY	HEIGHT	WIDTH	DEPTH
SINGLE FACED FIXED UNIT (A)	1 No	2286	3660	406
DOUBLE FACED MOBILE UNIT (B)	10Nos	2286	3660	812
DOUBLE FACED MOBILE UNIT WITH DOOR(C)	1No	2286	3660	812
DIMENSION IN MM				